

CONNECTOR SELECTION GUIDE



FOR USE WITH PRODUCTS
MANUFACTURED BY:



This guide lists popular options for Simpson Strong-Tie hangers used with engineered wood products. Not all available hanger and installation combinations are listed. Use in conjunction with the current Simpson Strong-Tie **Wood Construction Connectors** catalog for detailed hanger information.

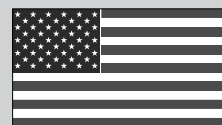

**ALLOWABLE
STRESS DESIGN**

DISTRIBUTED BY:

**800-999-5099
www.strongtie.com**

CSG-NORDIC07 7/07
exp. 6/09

CONNECTOR SELECTOR NOTES



General Notes

- See current *Wood Construction Connectors* catalog for important information and General Notes section and for hanger models, joist sizes, and header situations not shown. See pages 10-12 of this guide for installation information.
- Unless otherwise noted, downloads listed address hanger/header/fastener limitations assuming header material is Douglas Fir-Larch or Spruce Pine Fir. For LVL and glulam headers made primarily of Douglas Fir/Southern Pine, use the values found in the DF column. For LVL and glulam headers made primarily from Spruce Pine Fir or similar less dense veneers, use the values found in the SPF column. Loads are in pounds. Joist reaction should be checked by a qualified designer to ensure proper hanger selection.
- Uplift loads listed assume SPF joist and header and have been increased by 33% for earthquake and wind loading. Reduce loads according to code for normal duration loading such as cantilever construction.
- If hanger height is less than 60% of joist height, joist rotation may occur; see information below.
- Top flange hanger configuration and thickness of top flange need to be considered for flush frame conditions, see page 10.
- For this publication, carrying members are assumed to be at least 5½ inches tall. The horizontal thickness of the carrying member must be at least the length of nail being used or the hanger top flange dimension, whichever is greater.
Exception: narrower carrying members may be used with face mount hangers but the horizontal thickness must be at least 1¾ inches for 10d nails; 2 inches for 16d nails. Clinch nails on back side.
- THAI hangers in this publication are based on a "top flange" installation and require that the carrying member have a horizontal thickness of at least 2½ inches. Backer blocks are required when the header is an I-joist.
- All nails shown are common nails unless otherwise noted.
- I-joists that are used as headers require backer blocks. See Wood I-Joist Headers below for additional information.
- Multiple Members:** Multiple members should be adequately connected together to act as one unit.

Wood I-Joist Headers

I-Joist Headers: When supporting one I-joist from another, backer blocks must be used. Backer blocks are to be made from plywood, OSB, or dimension lumber. The thickness of a backer block should be the same thickness as the void in the side of the I-joist and a minimum of 12" wide. Attach with 10-10d common nails clinched as necessary, prior to installing the hanger. For Top Flange hangers, install backer blocks tight to top flange. For Face Mount hangers, install backer blocks tight to bottom flange. Refer to I-Joist manufacturer literature for specific guidelines.

Use 10dx1½" nails for all Top Flange hangers attached to an I-joist header. See table for allowable loads.

Model No.	I-Joist Header Flange Material ¹	
	DF/SCL	SPF
ITS	1085	940
ITT	1050	755
MIT	1230	885
LBV	1495	1340
BA	1495	1495

1. For flanges with thicknesses from 1½" to 1¾", use 0.85 of the I-joist header load. For flanges with thicknesses from 1¾" to 1¼", use 0.75 of the I-joist header load.

Face Mount hangers using 16d nails with headers having a flange width less than 2" wide but at least 1½" wide, apply a reduction factor of 0.75 to all table loads.

For face mount hangers using 10d nails with headers less than 1¾" wide horizontally but at least 1½" wide, apply a reduction factor of 0.85 to all table loads.

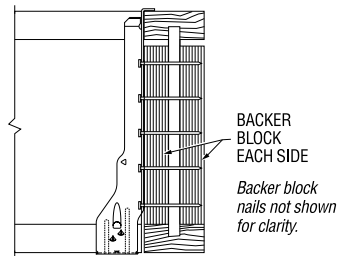

Face Mount

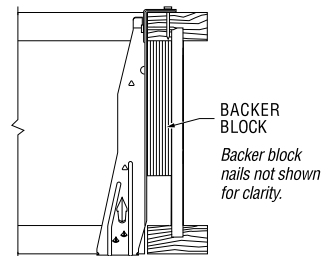

Top Flange

Sloped Joists: For sloped joists up to ¼:12, there is no reduction of load. For slopes greater than ¼:12 up to ½:12, see table.

Note: For joists sloped up to ¾:12, WP and HW hangers can be used with a reduction of 15%.

Sloped Joist	
Model	Reduction
ITS, IUS, ITT, MIT, MIU, LBV, B, HB	10%
WP, HW	15%

Prevent Rotation

Hangers provide some joist rotation resistance; however, additional lateral restraint may be required for deep joists.

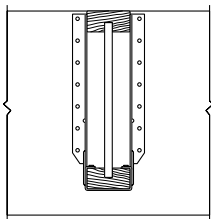

No Web Stiffener Installed
Hanger side flange supports joist top flange.

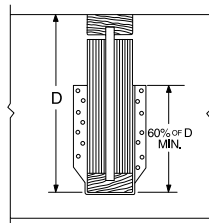

Web Stiffener Required
Hanger side flange should be at least 60% of joist depth or potential joist rotation must be addressed.

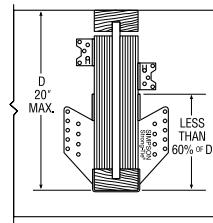

Rotation Resistance
If non-skewed hanger side flange is less than 60% of joist depth, attach staggered A34 framing anchors above the hanger.

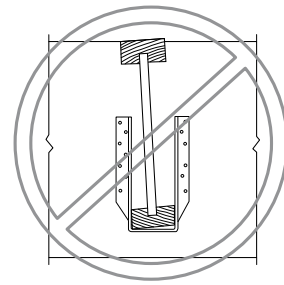

No Web Stiffener Results in Rotation
Hanger side flange is below the joist top flange. No web stiffener results in rotation, unless restrained by other means.

HOW TO PICK A HANGER

Follow these simple steps to choose your hanger:



1	Find your joist size in this guide.
2	Choose your header type. Solid header or I-joist. <ul style="list-style-type: none">• Solid headers include solid sawn Douglas Fir, Spruce-Pine Fir, and LVL.• For I-joist header see page 2.
3	Locate your connector type in the table. <ul style="list-style-type: none">• Face mount, top flange, skewed, sloped, etc.
4	Select a hanger from the table.
5	Confirm that your joist load is less than the hanger load. If yes, you have successfully selected your hanger.
	If you did not find a suitable hanger; Please see the current <i>Wood Construction Connectors</i> catalog or call Simpson Strong-Tie at (800) 999-5099. You will need the following information: <ul style="list-style-type: none">• Download• Uplift• Header condition• Bearing length requirement

SINGLE I-JOISTS - U.S./Allowable Load (lb.)

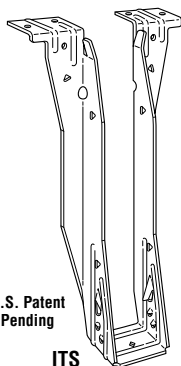

Joist Height	Top Flange						Face Mount						45° Skew								
	Model	B Dim	Fastener Type		Uplift (133)	Download	Model	B Dim	Fastener Type		Uplift (133)	Download	Model	B Dim	Fastener Type		Uplift (133)	Download			
			Header	Joist					Header	Joist					Header	Joist			DF	SPF	
NI-20², NI-40x², NI-60																					
Joist Width = 2 1/2"																					
9 1/2	ITS2.56/9.5	2	6-10d	—	105	1520	1150	IUS2.56/9.5	2	8-10d	—	75	935	810	SUR/L2.56/9	3 3/16	14-16d	2-10dx1 1/2	180	2015	1735
11 7/8	ITS2.56/11.88	2	6-10d	—	105	1520	1150	IUS2.56/11.88	2	10-10d	—	75	1170	1010	SUR/L2.56/11	3 3/16	16-16d	2-10dx1 1/2	180	2305	1980
14	ITS2.56/14	2	6-10d	—	105	1520	1150	IUS2.56/14	2	12-10d	—	75	1405	1210	SUR/L2.56/14	3 3/16	18-16d	2-10dx1 1/2	180	2590	2225
16	ITT316	2	6-10d	2-10dx1 1/2	245	1450	1200	IUS2.56/16	2	14-10d	—	75	1640	1415	SUR/L2.56/14	3 3/16	18-16d	2-10dx1 1/2	180	2590	2225
NI-80																					
Joist Width = 3 1/2"																					
11 7/8	ITT411.88	2	6-10d	2-10dx1 1/2	245	1450	1200	IUS3.56/11.88	2	12-10d	—	75	1405	1210	SUR/L410	2 5/8	14-16d	6-16d	920	1860	1610
14	ITT414	2	6-10d	2-10dx1 1/2	245	1450	1200	IUS3.56/14	2	12-10d	—	75	1405	1210	SUR/L414	2 1/2	18-16d	8-16d	1225	2395	1795
16	ITT416	2	6-10d	2-10dx1 1/2	245	1450	1200	IUS3.56/16	2	14-10d	—	75	1640	1415	SUR/L414	2 1/2	18-16d	8-16d	1225	2395	1795

1. Shaded hangers require web stiffeners at joist ends. Web stiffeners may be required for non-shaded hangers by I-Joist manufacturer.
2. Joist types may not be available in all depths shown on chart, check with manufacturer.
3. THAI hangers require a minimum of 4 top and 2 face nails installed (see note, page 2)
4. The B Dim is the depth of the hanger.

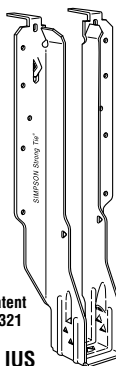
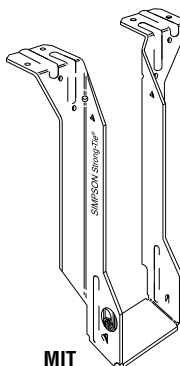
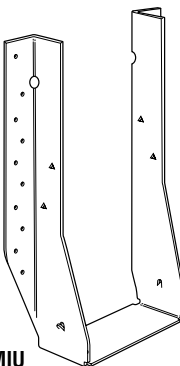
 <p>ITS</p> <p>U.S. Patent Pending</p>	 <p>ITT</p> <p>U.S. Patent 5,555,694</p>	 <p>IUS</p> <p>U.S. Patent 6,523,321</p>	 <p>MIT</p>	 <p>MIU</p>
<p>ITS – 18 gauge The new ITS top flange hanger with its Strong-Grip™ seat and Funnel Flange™ secures I-joists with flange thicknesses from 1 1/8" – 1 1/2" and installs faster than any other top flange hanger. Joist nails are not required.</p>	<p>ITT – 18 gauge The ITT bend-tabs help reduce squeaks. Features uplift capacity and extended seat design (to allow installation of slightly undercut joists).</p>	<p>IUS – 18 gauge The IUS is a hybrid hanger that incorporates the advantages of face-mount and top-flange hangers. Joist nails are not required.</p>	<p>MIT – 16 gauge The MIT's Positive Angle Nailing helps minimize splitting of the I-joist's bottom flange. Features uplift capacity and extended seat design (to allow installation of slightly undercut joists).</p>	<p>MIU – 16 gauge The MIU series features 16 gauge steel and extra nailing for higher loads.</p>

SINGLE I-JOISTS - U.S./Allowable Load (lb.)

Joist Height	Adjustable Height								Field Slope & Skew						
	Model	B Dim	Fastener Type			Uplift (133)	Download		Model	B Dim	Fastener Type		Uplift (133)	Download	
			Header		Joist		DF	SPF			Header	Joist		DF	SPF
			Top	Face											
NI-20², NI-40x², NI-60													Joist Width = 2½"		
9½	THAI322	2¼	4-10d	2-10d	2-10dx1½	—	1715	1590	LSSUH310	3½	14-16d	12-10dx1½	990	1600	1385
11⅞	THAI322	2¼	4-10d	2-10d	2-10dx1½	—	1715	1590	LSSUH310	3½	14-16d	12-10dx1½	990	1600	1385
14	THAI322	2¼	4-10d	2-10d	2-10dx1½	—	1715	1590	LSSUH310	3½	14-16d	12-10dx1½	990	1600	1385
16	See <i>Wood Construction Connectors</i> catalog for hanger selection								See <i>Wood Construction Connectors</i> catalog for hanger selection						
NI-80													Joist Width = 3½"		
11⅞	THAI422	2¼	4-10d	2-10d	2-10dx1½	—	1715	1590	LSSU410	3½	14-16d	12-10dx1½	990	1625	1365
14	THAI422	2¼	4-10d	2-10d	2-10dx1½	—	1715	1590	LSSU410	3½	14-16d	12-10dx1½	990	1625	1365
16	See <i>Wood Construction Connectors</i> catalog for hanger selection								See <i>Wood Construction Connectors</i> catalog for hanger selection						

1. See notes on page 4.

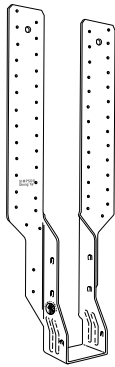

THAI

THAI – 18 gauge
This hanger has extra long straps and can be field-formed to give height adjustability and top flange hanger convenience. Positive angle nailing helps minimize splitting of the I-joist's bottom flange. Minimum nailing is shown in the table above. Strap must be field-formed over the top of the header by a minimum of 2½". Web stiffeners required when used with I-joists.

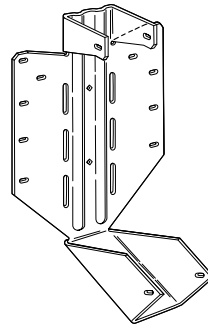

LSSU

LSSU, LSSUI – 18 gauge
LSSU210-2, LSSU410, and LSSUH310 – 16 gauge
LSU – 14 gauge
LSSU models provide uplift capacity and can be field sloped and/or skewed to 45°. Web stiffeners required when used with I-joists; cut web stiffener to match angle on sloped conditions.

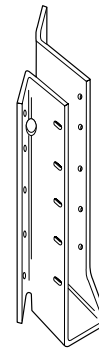

SUL

SUR/L, SUR/LI – 16 gauge
HSUR/L – 14 gauge
All models are skewed 45°. Normally accommodates a 40° - 50° skew. The installation of these hangers does not require a beveled end cut.

DOUBLE I-JOISTS - U.S./Allowable Load (lb.)



Joist Height	Top Flange						Face Mount						45° Skew								
	Model	B Dim	Fastener Type		Uplift (133)	Download		Model	B Dim	Fastener Type		Uplift (133)	Download		Model	B Dim	Fastener Type		Uplift (133)	Download	
			Header	Joist		DF	SPF			Header	Joist		DF	SPF			Header	Joist		DF	SPF
Double NI-20², NI-40x³, NI-60																					
Joist Width = 5"																					
9½	MIT39.5-2	2½	8-16d	2-10dx1½	200	2305	1665	MIU5.12/9	2½	16-16d	2-10dx1½	200	2270	1970	HSUR/L5.12/9	2¼	12-16d	2-10dx1½	120	1655	1440
11¾	MIT311.88-2	2½	8-16d	2-10dx1½	200	2305	1665	MIU5.12/11	2½	20-16d	2-10dx1½	200	2840	2460	HSUR/L5.12/11	2¼	16-16d	2-10dx1½	120	2210	1920
14	MIT314-2	2½	8-16d	2-10dx1½	200	2305	1665	MIU5.12/14	2½	22-16d	2-10dx1½	200	3125	2705	HSUR/L5.12/14	2¼	20-16d	2-10dx1½	120	2760	2400
16	MIT5.12/16	2½	8-16d	2-10dx1½	200	2305	1665	MIU5.12/16	2½	24-16d	2-10dx1½	200	3410	2950	HSUR/L5.12/16	2¼	24-16d	2-10dx1½	120	3050	2410
Double NI-80																					
Joist Width = 7"																					
11¾	B7.12/11.88	2½	14-16d	6-16d	850	3800	2650	HU412-2	2½	22-16d	8-16d	1245	2950	2550	HU412-2X ²	2½	22-16d	8-16d	900	2950	2550
14	B7.12/14	2½	14-16d	6-16d	850	3800	2650	HU414-2	2½	26-16d	12-16d	1800	3485	3015	HU414-2X ²	2½	26-16d	12-16d	1350	3485	3015
16	B7.12/16	2½	14-16d	6-16d	850	3800	2650	HU414-2	2½	26-16d	12-16d	1800	3485	3015	HU414-2X ²	2½	26-16d	12-16d	1350	3485	3015

1. Shaded hangers require web stiffeners at joist ends. Web stiffeners may be required for non-shaded hangers by I-Joist manufacturer.
2. Skewed option must be special ordered. Specify skew angle and direction (e.g. HU412-2X SKR45°).
3. Joist types may not be available in all depths shown. Check with manufacturer.
4. THAI-2 must be special ordered. Specify width between 3⅛" and 5⅝"
5. LSU is field sloped only. Skewed option must be factory ordered.
6. The B Dim is the depth of the hanger.

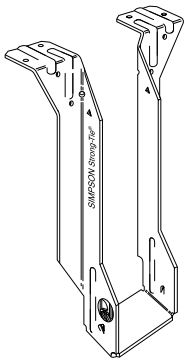

MIT

MIT – 16 gauge

The MIT's Positive Angle Nailing helps minimize splitting of the I-joists' bottom flange. Features uplift capacity and extended seat design (to allow installation of slightly undercut joists).

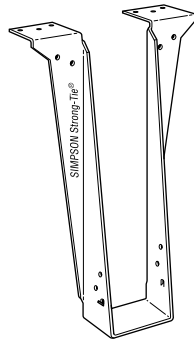

LBV

LBV – 14 gauge

The LBV is designed especially for use with multiple ply headers 1½" to 1¾" thick, and may be used for weld-on applications.

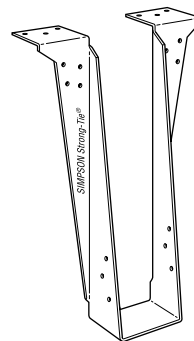

B

B – 12 gauge

The B series offers versatility for I-joists and SCL lumber. Enhanced load capacity widens the range of applications for these hangers.

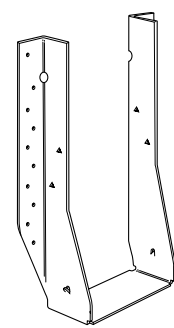

MIU

MIU – 16 gauge

The MIU series features 16 gauge steel and extra nailing for higher loads.

DOUBLE I-JOISTS - U.S./Allowable Load (lb.)

Joist Height	Adjustable Height								Field Slope & Skew							
	Model	B Dim	Fastener Type			Uplift (133)	Download		Model	B Dim	Fastener Type		Uplift (133)	Download		
			Header		Joist		DF	SPF			Header	Joist		DF	SPF	
			Top	Face												
Double NI-20², NI-40x³, NI-60									Joist Width = 5"							
9½	THAI-2 ⁴	2½	4-10d	2-10d	2-10dx1½	—	2020	2020	LSU5.12 ⁵	3½	24-16d	16-10dx1½	760	1790	1550	
11⅞	THAI-2 ⁴	2½	4-10d	2-10d	2-10dx1½	—	2020	2020	LSU5.12 ⁵	3½	24-16d	16-10dx1½	760	1790	1550	
14	THAI-2 ⁴	2½	4-10d	2-10d	2-10dx1½	—	2020	2020	LSU5.12 ⁵	3½	24-16d	16-10dx1½	760	1790	1550	
16	See Wood Construction Connectors catalog for hanger selection								See Wood Construction Connectors catalog for hanger selection							
Double NI-80									Joist Width = 7"							
11⅞	See Wood Construction Connectors catalog for hanger selection								See Wood Construction Connectors catalog for hanger selection							
14	See Wood Construction Connectors catalog for hanger selection								See Wood Construction Connectors catalog for hanger selection							
16	See Wood Construction Connectors catalog for hanger selection								See Wood Construction Connectors catalog for hanger selection							

1. See notes on page 6.

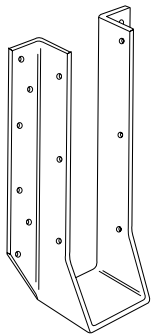

HU

HU – 14 gauge
The HU series features uplift capacity and a large selection of sizes and load ranges. HU hangers have triangle holes that can be filled for increased loads. Web stiffeners required when used with I-joists.

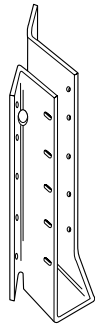

SUL

SUR/L – 16 gauge
HSUR/L – 14 gauge
All models are skewed 45°. Normally accommodates a 40°- 50° skew. The installation of these hangers does not require a beveled end cut.

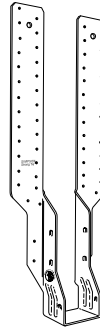

THAI

THAI – 18 gauge
THAI-2 – 14 gauge
This hanger has extra long straps and can be field-formed to give height adjustability and top flange hanger convenience. Positive angle nailing helps minimize splitting of the I-joist's bottom flange. Minimum nailing is shown in the table above. Strap must be field-formed over the top of the header by a minimum of 2½". Web stiffeners required when used with I-joists.

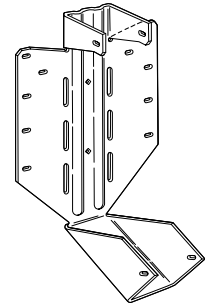

LSSU

LSSU, LSSUI – 18 gauge
LSSU210-2, LSSU410 – 16 gauge
LSU – 14 gauge
LSSU models provide uplift capacity and can be field sloped and/or skewed to 45°. Web stiffeners required when used with I-joists.

BEAMS and HEADERS - U.S./Allowable Load (lb.)



Joist Height	Top Flange						Face Mount					
	Model	B Dim	Fastener Type		Uplift (133)	Download SPF	Model	B Dim	Fastener Type		Uplift (133)	Download SPF
			Header	Joist					Header	Joist		
1 3/4" NORDIC LAM												
9 1/2	MIT9.5	2 1/2	8-16d	2-10dx1 1/2	200	1665	HU9	2 1/2	24-16d	10-10dx1 1/2	1010	2785
	LBV1.81/9.5	3	10-16d	2-10dx1 1/2	220	1830	HUS1.81/10	3	30-16d	10-16d	2390	4355
11 7/8	MIT11.88	2 1/2	8-16d	2-10dx1 1/2	200	1665	HU11	2 1/2	30-16d	10-10dx1 1/2	1010	3480
	BA1.81/11.88	3	16-16d	8-10dx1 1/2	885	2665	HUS1.81/10	3	30-16d	10-16d	2390	4355
14	MIT1.81/14	2 1/2	8-16d	2-10dx1 1/2	200	1665	HU14	2 1/2	36-16d	14-10dx1 1/2	1410	4175
	LBV1.81/14	3	10-16d	2-10dx1 1/2	220	1830	HUS1.81/10	3	30-16d	10-16d	2390	4355
16	MIT1.81/16	2 1/2	8-16d	2-10dx1 1/2	200	1665	MIU1.81/16	2 1/2	24-16d	2-10dx1 1/2	200	2950
	B1.81/16	3	14-16d	6-10dx1 1/2	695	2665	HU14	2 1/2	36-16d	14-10dx1 1/2	1410	4175
18	LBV1.81X ³	3	10-16d	2-10dx1 1/2	220	1830	MIU1.81/18	2 1/2	26-16d	2-10dx1 1/2	200	3200
	B1.81X ³	3	14-16d	6-10dx1 1/2	695	2665	HU14	2 1/2	36-16d	14-10dx1 1/2	1410	4175
2 1/2" NORDIC LAM												
9 1/2	LBV2.56/9.5	2 1/2	10-16d	2-10dx1 1/2	220	1830	HU2.75/10	2 1/2	18-16d	10-10dx1 1/2	1010	2090
	B2.56/9.5	2 1/2	14-16d	6-16dx2 1/2	850	2650	HGUS2.75/10	4	46-16d	16-16d	3050	5980
11 7/8	MIT311.88	2 1/2	8-16d	2-10dx1 1/2	200	1665	HU2.75/12	2 1/2	22-16d	10-10dx1 1/2	1010	2550
	BA2.56/11.88	3	16-16d	8-10dx1 1/2	885	2665	HGUS2.75/12	4	56-16d	20-16d	3405	6335
14	BA2.56/14	3	16-16d	8-10dx1 1/2	885	2665	HU2.75/14	2 1/2	24-16d	14-10dx1 1/2	1410	2785
	WPU2.56/14	3	7-16d	6-10dx1 1/2	650	4165	HGUS2.75/14	4	66-16d	22-16d	4520	6510
16	BA2.56/16	3	16-16d	8-10dx1 1/2	885	2665	HU2.75/16	2 1/2	26-16d	14-10dx1 1/2	1410	3015
	HWU2.56/16	4	8-16d	6-10dx1 1/2	640	5415	HGUS2.75/14	4	66-16d	22-16d	4520	6510
18	WPU2.56/18	3	7-16d	6-10dx1 1/2	650	4165	HU2.75/16	2 1/2	26-16d	14-10dx1 1/2	1410	3015
	HWU2.56/18	4	8-16d	6-10dx1 1/2	640	5415	HGUS2.75/14	4	66-16d	22-16d	4520	6510
2-PLY 1 3/4" OR 3 1/2" NORDIC LAM												
9 1/2	LBV3.56/9.5	2 1/2	10-16d	2-10dx1 1/2	200	1830	HHUS410	3	30-16d	10-16d	2400	4385
	HB3.56/9.5	3 1/2	22-16d	10-16d	1825	3820	HGUS410	4	46-16d	16-16d	3050	7365
11 7/8	BA3.56/11.88	3	16-16d	8-10dx1 1/2	885	2665	HHUS410	3	30-16d	10-16d	2400	4385
	HB3.56/11.88	3 1/2	22-16d	10-16d	1825	3820	HGUS412	4	56-16d	20-16d	3405	7690
14	BA3.56/14	3	16-16d	8-10dx1 1/2	885	2665	HHUS410	3	30-16d	10-16d	2400	4385
	GLTV3.514	5	10-16d	6-16d	1150	4260	HGUS414	4	66-16d	22-16d	4520	7890
16	BA3.56/16	3	16-16d	8-10dx1 1/2	885	2665	HHUS410	3	30-16d	10-16d	2400	4385
	GLTV3.516	5	10-16d	6-16d	1150	4260	HGUS414	4	66-16d	22-16d	4520	7890
18	HB3.56/18	3 1/2	22-16d	10-16d	1825	3820	HHUS410	3	30-16d	10-16d	2400	4385
	HGLTV3.518	6	18-16d	6-16d	1150	6690	HGUS414	4	66-16d	22-16d	4520	7890

1. HU and BA hangers use both round and triangle holes.
2. See page 2, note 2 for header definitions.
3. When ordering EGQ, HGU, HHGU, B1.81X or LBV1.81X, specify height.
4. The B Dim is the height of the hanger.

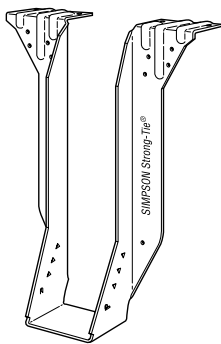

BA

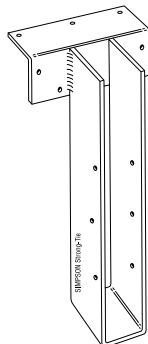

WPU

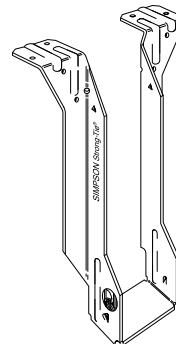

MIT

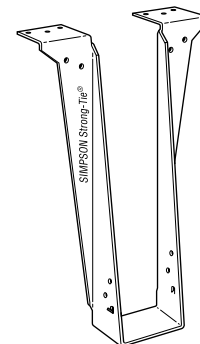

LBV

BA – 14 gauge
The BA series offers versatility for I-joists and SCL lumber. Enhanced load capacity widens the range of applications for these hangers.

W, WI: Top flange – 12 gauge; Stirrup – 12 gauge
WP, WPI, WPU: Top flange – 7 gauge; Stirrup – 12 gauge
HWU: Top flange – 3 gauge; Stirrup – 10 gauge
This welded series offers the greatest design flexibility and versatility, and a large selection of sizes. Suitable for welded and nailer applications, and modifications including slopes and skews.

MIT – 16 gauge
The MIT's Positive Angle Nailing helps minimize splitting of the I-joists' bottom flange. Features uplift capacity and extended seat design (to allow installation of slightly undercut joists).

LBV – 14 gauge
The LBV is designed especially for use with multiple ply headers 1 1/2" to 1 3/4" thick, and may be used for weld-on applications.

BEAMS and HEADERS - U.S./Allowable Load (lb.)

Joist Height	Top Flange						Face Mount					
	Model	B Dim	Fastener Type		Uplift (133)	Download SPF	Model	B Dim	Fastener Type		Uplift (133)	Download SPF
			Header	Joist					Header	Joist		
3-PLY 1 3/4" OR 5 1/2" NORDIC LAM												
9 1/2	HB5.50/9.5	3 1/2	22-16d	10-16d	1825	3820	HHUS5.50/10	3	30-16d	10-16d	2400	4385
	GLTV5.59	5	10-16d	6-16d	1150	4260	HGUS5.50/10	4	46-16d	16-16d	3050	7510
11 7/8	HB5.50/11.88	3 1/2	22-16d	10-16d	1825	3820	HHUS5.50/10	3	30-16d	10-16d	2400	4385
	HGLTV5.511	6	18-16d	6-16d	1150	6690	HGUS5.50/12	4	56-16d	20-16d	3405	7690
14	HB5.50/14	3 1/2	22-16d	10-16d	1825	3820	HHUS5.50/10	3	30-16d	10-16d	2400	4385
	EGQ5.50-SDS ³	6	28-SDS 1/4x3	12-SDS 1/4x3	4135	15600	HGUS5.50/14	4	66-16d	22-16d	4520	8415
16	HB5.50/16	3 1/2	22-16d	10-16d	1825	3820	HHUS5.50/10	3	30-16d	10-16d	2400	4385
	EGQ5.50-SDS ³	6	28-SDS 1/4x3	12-SDS 1/4x3	4135	15600	HGUS5.50/14	4	66-16d	22-16d	4520	8415
18	HGLTV5.518	6	18-16d	6-16d	1150	6690	HGUS5.50/14	4	66-16d	22-16d	4520	8415
	EGQ5.50-SDS ³	6	28-SDS 1/4x3	12-SDS 1/4x3	4135	15600	HGU5.50 ³	5 1/4	36-SDS 1/2x2 1/2	24-SDS 1/4x2 1/2	8310	11810
4-PLY 1 3/4" OR 7" NORDIC LAM												
9 1/2	HB7.12/9.5	3 1/2	22-16d	10-16d	1825	3820	HHUS7.25/10	3 5/16	30-16d	10-16d	2400	4385
	GLTV49.5-2	5	10-16d	6-16d	1150	4260	HGUS7.25/10	4	46-16d	16-16d	3050	7595
11 7/8	HB7.12/11.88	3 1/2	22-16d	10-16d	1825	3820	HHUS7.25/10	3 5/16	30-16d	10-16d	2400	4385
	EGQ7.25-SDS ³	6	28-SDS 1/4x3	12-SDS 1/4x3	4135	15600	HGUS7.25/12	4	56-16d	20-16d	3405	8260
14	GLTV414-2	5	10-16d	6-16d	1150	4260	HGUS7.25/14	4	66-16d	22-16d	4520	9330
	EGQ7.25-SDS ³	6	28-SDS 1/4x3	12-SDS 1/4x3	4135	15600	HGU7.25 ³	5 1/4	36-SDS 1/4x2 1/2	24-SDS 1/4x2 1/2	8310	11810
16	HGLTV416-2	6	18-16d	6-16d	1150	6690	HGUS7.25/14	4	66-16d	22-16d	4520	9330
	EGQ7.25-SDS ³	6	28-SDS 1/4x3	12-SDS 1/4x3	4135	15600	HHGU7.25 ³	5 1/4	44-SDS 1/4x2 1/2	28-SDS 1/4x2 1/2	11745	14030
18	HGLTV418-2	6	18-16d	6-16d	1150	6690	HGUS7.25/14	4	66-16d	22-16d	4520	9330
	EGQ7.25-SDS ³	6	28-SDS 1/4x3	12-SDS 1/4x3	4135	15600	HHGU7.25 ³	5 1/4	44-SDS 1/4x2 1/2	28-SDS 1/4x2 1/2	11745	14030

1. See notes on page 8.

Form CSG-NORDIC07 © 2007 SIMPSON STRONG-TIE CO., INC.

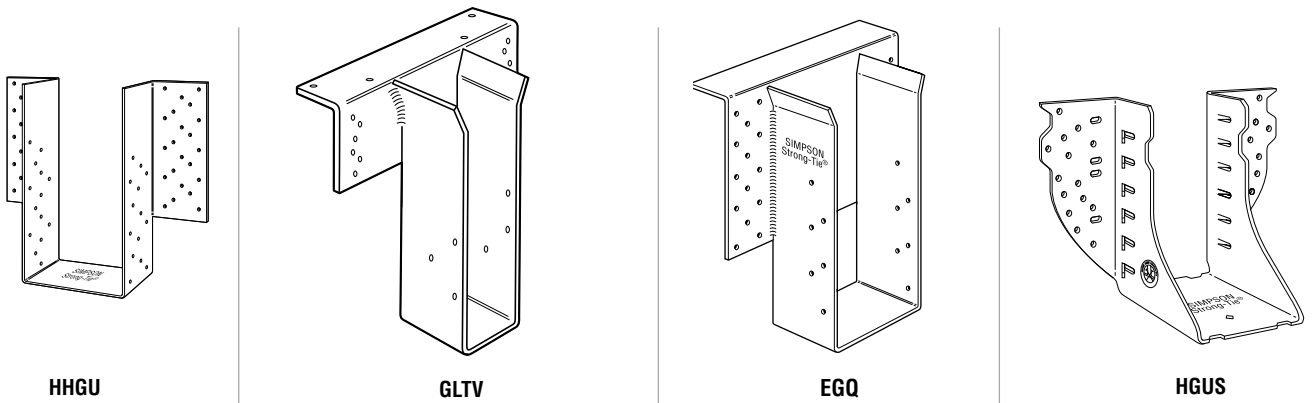

HHGU – 7 gauge
HHGU – 3 gauge

The GU hangers are a high-capacity girder hanger designed for situations where the header and joist are flush at top.

GLTV & HGLTV: Top flange – 3 gauge
Stirrup – 7 gauge

This welded series provides high load carrying capacity and design flexibility and versatility. May be sloped, skewed and modified in other ways, and may be welded to steel I-beams. The GLTV may be used on 4x nailers.

EGQ: Top flange – 3 gauge
Stirrup – 7 gauge

A high capacity top flange connector designed for use with Structural Composite Lumber beams.

HGUS: 12 gauge
HHUS: 14 gauge

Features double shear nailing for high strength and lowest installed cost due to the reduced nail quantity requirement. **Not suitable for use with I-joists.**

GENERAL CONNECTOR INSTALLATION

Top Flange Hangers

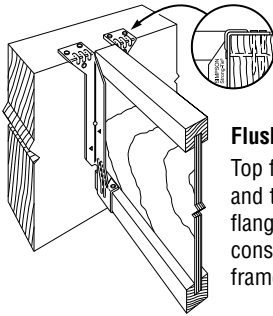

Flush Framing
Top flange configuration and thickness of top flange need to be considered for flush frame conditions.

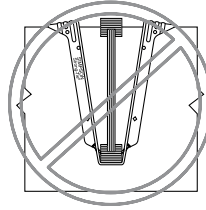

Hanger Over-Spread
If the hanger is over-spread, it can raise the I-Joist above the header and may cause uneven surfaces and squeaky floors.

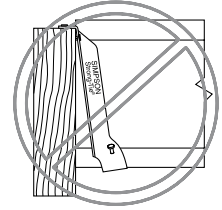

Hanger Not Plumb
A hanger "kicked out" from the header can cause uneven surfaces and squeaky floors.

Wood Nailers

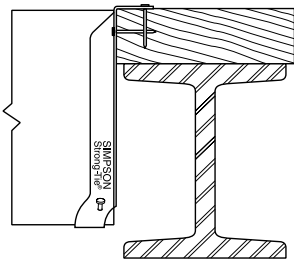

Correct Attachment

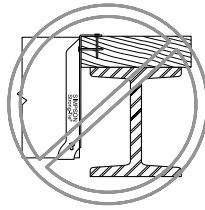

Nailer Too Wide
The loading may cause cross-grain bending. As a general rule, the maximum allowable overhang is 1/4", depending on nailer thickness.

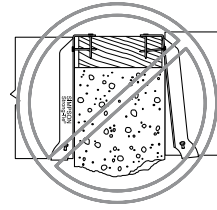

Nailer Too Narrow
A maximum mismatch of 1/8" for normal installations is acceptable.

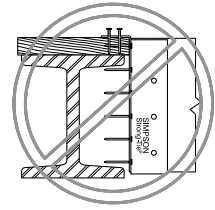

Nailer Too Thin and the wrong hanger for a nailer application.

Nail Hole Shapes

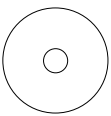

Round Holes
All holes must be filled except for the THAI adjustable height hanger. Refer to load tables for THAI nail quantities.



Triangle Holes
Provided on some products in addition to round holes. Round and triangle holes must be filled to achieve the published maximum load value.

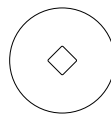

Diamond Holes
Optional holes to temporarily secure connectors to the member during installation.

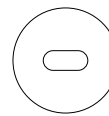

Obround Holes
Used to provide easier nailing access in tight locations. All holes must be filled except for the LSSU hanger when skewed. Refer to load tables for LSSU nail quantities.

Toe Nailed I-Joist

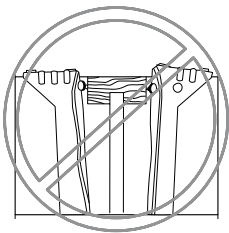

Toe nailing causes squeaks and improper hanger installations. **Do not toe nail I-joists prior to installing either top flange or face mount hangers.**

Alternate Joist Installation with NO JOIST NAILS

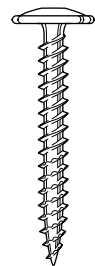

SD8x1.25
(Actual Size)

Install Simpson's SD8x1.25 screw through the existing hole in the bottom of the seat. It is not necessary to bend tabs or install nails through tabs in IUT and ITT hangers. This installation works for I-joists with 1 1/8" or greater depth of bottom flange. This application is not recommended for seat widths > 2 3/4".

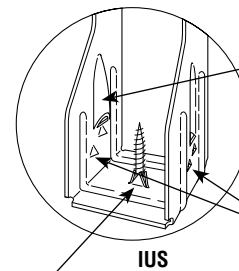

Snap-In Teardrop
No nails required!

Strong-Grip™ holds bottom chord in position

Starburst detail allows secure seating of joist.

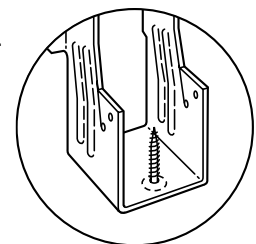

ITT

Double Shear Nailing

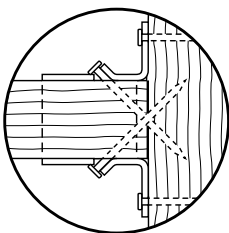

The nail is installed into joist and header, distributing load through two points on each nail for greater strength.

Model No.	Joist Fasteners	Uplift (133)			
		Joist Widths			
		1 1/2 - 1 3/4		2 - 2 1/2	
		DF	SPF	DF	SPF
IUS	Simpson SD8x1.25 Tapping Screw ¹	150	130	95	95
ITT		130	110	65	65
ITS		Screw in the seat is not recommended for the ITS			

1. Any #8x1.25 self-drilling screw may be used.

GENERAL CONNECTOR INSTALLATION

ITS Installation Sequence (IUS Similar)

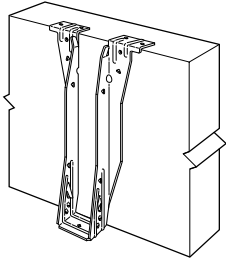

STEP 1
Attach the ITS to the header

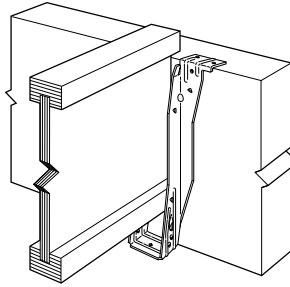

STEP 2
Slide the I-joint downward into the ITS until it rests above the Strong-Grip™ seat.

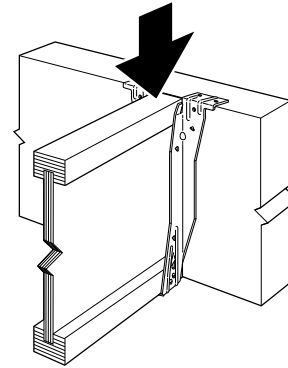

STEP 3
Firmly push or snap I-joint fully into the seat of the ITS.

IUT & ITT Tab Installation (VPA Similar)

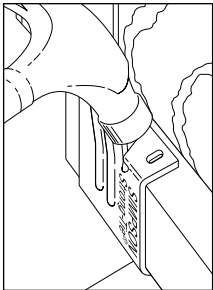

Bend the tab with a hammer.

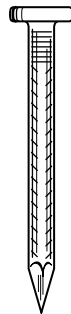

ACTUAL SIZE
Use a 10d x 1 1/2" nail (Simpson's N10 nail shown).

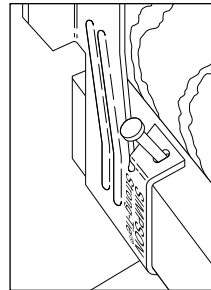

Hammer the nail in at approx. 45° angle to limit splitting.

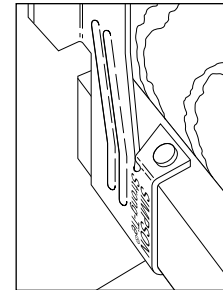

The tab is now correctly installed.

VPA Installation

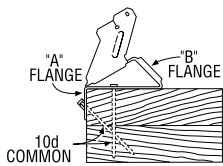

Step 1
Install top nails and face PAN nails in "A" flange to outside wall top plate.

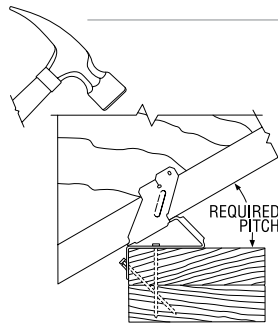

Step 2
Seat rafter with a hammer, adjusting "B" flange to the required pitch.

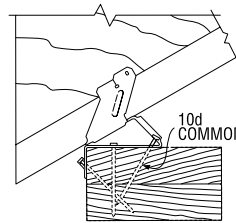

Step 3
Install "B" flange nails in the obround nail holes, locking the pitch.

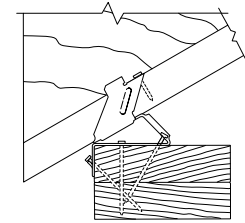

Step 4
Bend tab with hammer and install nail into tab nail hole. Hammer nail in at approx. 45° angle to limit splitting.

LSSU Installation

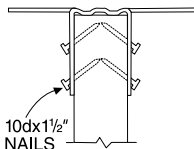

1. Nail hanger to slope-cut joist, installing seat nail first. No bevel necessary for skewed installation.

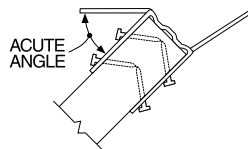

2. Skew flange to form acute angle. Bend other flange back. Bend along the centerline of slots. Bend one time only.

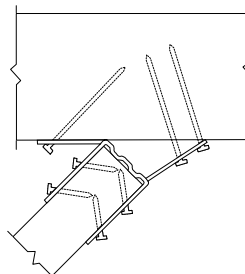

3. Attach hanger to header, acute angle first. Install nails at an angle.

THAI Minimum Nailing

MINIMUM OF 2 1/2" OF TOP FLANGE MATERIAL FOR MINIMUM NAILING CONFIGURATION

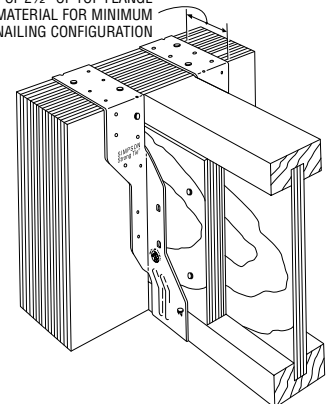

GENERAL CONNECTOR INSTALLATION



TB - Tension Bridging

Joist Height	Joist Spacing (Inches)								
	12	16	19.2	24	30	32	36	42	48
9½	TB20	TB27	TB27	TB30	TB36	TB36	TB42	TB48	TB54
11⅞	TB20	TB27	TB27	TB30	TB36	TB36	TB42	TB48	TB54
14	TB27	TB27	TB27	TB36	TB36	TB42	TB42	TB48	TB54
16	TB27	TB27	TB30	TB36	TB42	TB42	TB42	TB48	TB54

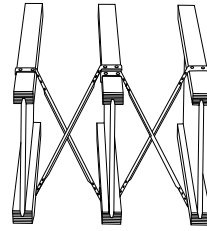

Typical TB Installation

VPA - Variable Pitch Connectors

Joist Width	Model No.	Fasteners		Allowable Loads							
		Top Plate	Rafter	Uplift (133)		Download (100)		Lateral Load (133)			
				DF/SP	SPF	DF/SP	SPF	DF/SP		SPF	
F ₁	F ₂	F ₁	F ₂								
2½	VPA3	9-10d	2-10dx1½	245	210	1230	1020	375	245	325	210
3½	VPA4	11-10d	2-10dx1½	245	210	1230	1020	375	245	325	210

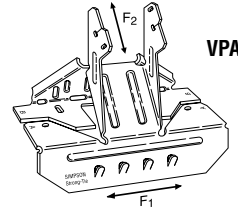

VPA - 18 gauge
This variable pitch connector allows a sloped beam to sit on a top plate without having to notch, birdmouth, bevel, or toe nail. It also provides uplift capacity. Adjustable from 3:12 to 12:12 pitch.

1. VPA's are not appropriate for applications that require more than 2" of bearing, such as intermediate supports.

STRONG-DRIVE® SCREWS INSTALLATION FOR NORDIC BEAMS

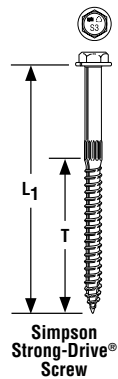

INSTALLATION

- Hex washer head allows for easy driving.
- Built-in reamer and type 17 tip means no pre-drilling required.
- See illustrations below for SDS positioning on different assemblies.
- Install with high-torque, low-speed drill (5 amp+).
- Do not over-drive the SDS screws.

DESIGN

- Allowable load values are derived from testing based on ASTM D-1761. The Designer shall apply adjustment factors per 2001 NDS. Loads shown are C_D = 1.0. Increase as allowed per code to a maximum C_D = 1.33.
- Loads shown are at 100%. Increase as allowed by code.
- The designer shall specify the location of all screws (*stagger screws on opposite faces*). Minimum recommended spacing—Wide Face: end distance 4", edge distance 1½", spacing parallel to grain 4", spacing perpendicular to grain 2".
- Uniform loads in the table below are based on the capacity of the fasteners to transfer loads between plies. The capacity of the beam may be less and should be checked by a qualified designer or with the manufacturer's literature.

Model	L ₁ (in)	T (in)	Head Stamp
SDS25312	3 1/2	2 1/4	S3.5
SDS25412	4 1/2	2 3/4	S4.5
SDS25600	6	3 1/4	S6

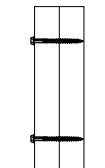

Assembly A
2 - 1¾"
SDS¼x3½

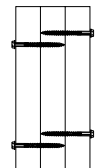

Assembly B1
3 - 1¾"
SDS¼x3½

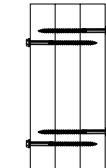

Assembly B2
3 - 1¾"
SDS¼x4½

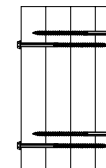

Assembly C
4 - 1¾"
SDS¼x6

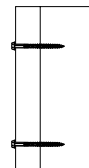

Assembly D
1 - 1¾", 1 - 3½"
SDS¼x3½

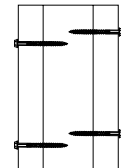

Assembly E
2 - 1¾", 1 - 3½"
SDS¼x3½



Assembly F
2 - 3½"
SDS¼x6

MAXIMUM ALLOWABLE UNIFORM LOAD (LBS PER LINEAL FT)							
Multiple Members		SDS Screws, 12" OC		SDS Screws, 16" OC		SDS Screws, 24" OC	
Assembly	Components	2 Rows	3 Rows	2 Rows	3 Rows	2 Rows	3 Rows
A	2 pieces (all 1¾)	884	1326	663	995	442	663
B1	3 pieces (all 1¾)	663	995	497	746	332	497
B2	3 pieces (all 1¾)	663	995	497	746	332	497
C	4 pieces (all 1¾)	589	884	442	663	295	442
D	2 pieces (1¾ - 3½)	663	995	497	746	332	497
E	3 pieces (1¾ - 3½ - 1¾)	589	884	442	663	295	442
F	2 pieces (3½ - 3½)	884	1326	663	995	442	663

1. If 7" wide beams are not equally loaded on each side, the plf load from the lesser side should be at least 25% of the opposite side.
2. Quantity and spacing of screws in table are for each screw head side of the assembly as shown in the Assembly figures above.
3. The design professional shall ensure that adequate lateral bracing is provided to prevent displacement of the beam due to the torsion created by the structural members framing into the side of the beam assembly.

Refer to the current **Wood Construction Connectors** catalog for General Notes, Warranty Information and other important information, including Terms and Conditions of Sale, Building Code Evaluation listings and Corrosion Resistance.

Home Office
5956 W. Las Positas Blvd.
Pleasanton, CA 94588
FAX: 925/847-1603

Northwest U.S.A.
5151 S. Airport Way
Stockton, CA 95206
FAX: 209/234-3868

Southwest U.S.A.
260 N. Palm Street
Brea, CA 92821
FAX: 714/871-9167

Northeast U.S.A.
2600 International Street
Columbus, OH 43228
FAX: 614/876-0636

Southeast U.S.A.
2221 Country Lane
McKinney, TX 75069
FAX: 972/542-5379

Eastern Canada
5 Kenview Blvd.
Brampton, ON L6T 5G5
FAX: 905/458-7274

Western Canada
11476 Kingston St.
Maple Ridge, BC V2X 0Y5
FAX: 604/465-0297

Warehouses & Manufacturing:
Eagan, MN; Enfield, CT;
Gallatin, TN; High Point, NC;
Jacksonville, FL; Kent, WA;
Langley, BC

800-999-5099
www.strongtie.com

© 2007
Simpson Strong-Tie Company Inc.
Printed in the U.S.A.

CSG-NORDIC07 6/07
exp. 6/09