

BM TRADA Certification

Chiltern House
 Stocking Lane
 Hughenden Valley
 High Wycombe
 United Kingdom
 Tel:+44 (0)1494 569700
 Fax:+44 (0)1494 565487
Enquiries@bmtrada.com
<http://www.bmtrada.com>

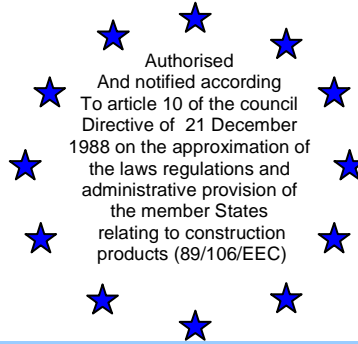

Member of EOTA

European Technical Approval ETA-09/0035

Original version in English

Trade name(s)	Norjoist Nordic Joist
Holder of approval	Nordic Engineered Wood Windsor Station, Suite 504 1100, de la Gauchetière W. Montreal (Quebec) H3B 2S2
Generic type and use of construction product	LIGHT COMPOSITE WOOD BASED BEAMS FOR STRUCTURAL PURPOSES
Validity:	From 25/06/2009 To 02/03/2014
Manufacturing plant(s)	Chantiers Chibougamau 521, chemin Merrill, C.P. 216 Chibougamau (Québec) G8P 2K7
This Approval contains	<i>10 pages and 4 Annexes</i>



European Organisation For Technical Approvals

I. LEGAL BASIS AND GENERAL CONDITIONS

1 This European Technical Approval is issued by BM TRADA certification in accordance with:

Council Directive 89/106/EEC of 21 December 1988 on the approximation of laws, regulations and administrative provisions of Member States relating to construction products¹, modified by Council Directive 93/68/EEC² and Regulation (EC) N° 1882/2003 of the European Parliament and of the Council³; Construction Product Regulations 1991 and the subsequent Construction Product (Amendment) Regulations 1994.

Common Procedural Rules for Requesting, Preparing and the Granting of European Technical Approvals set out in the Annex to Commission Decision 94/23/EC⁴;

Procedure for issuing ETA without an ETA Guideline in accordance with point 3.2 of the Common Procedural Rules, pursuant to Article 9(2) of the CPD).

2 BM TRADA Certification is authorised to check whether the provisions of this European Technical Approval are met. Checking may take place in the manufacturing plant(s). Nevertheless, the responsibility for the conformity of the products to the European Technical Approval and for their fitness for the intended use remains with the holder of the European Technical Approval.

3 This European Technical Approval is not to be transferred to manufacturers or agents of manufacturers other than those recorded in a comprehensive list maintained by BM TRADA and copied to EOTA.

4 This European Technical Approval may be withdrawn by BM TRADA Certification, in particular pursuant to information by the Commission according to Article 5(1) of Council Directive 89/106/EEC.

5 Reproduction of this European Technical Approval including transmission by electronic means shall be in full. However, partial reproduction can be made with the written consent of BM TRADA Certification. In this case partial reproduction has to be designated as such. Texts and drawings of advertising brochures shall not contradict or misuse the European Technical Approval.

6 The European Technical Approval is issued by the approval body in its official language. This version corresponds fully to the version circulated in EOTA. Translations into other languages have to be designated as such.

1 Official Journal of the European Communities N°L 40, 11.2.1989, p. 12

2 Official Journal of the European Communities N°L 220, 30.8.1993, p. 1

3 Official Journal of the European Union N°L 284, 31.10.2003, p. 1

4 Official Journal of the European Communities N°L 17, 20.1.1994, p. 34



II SPECIFIC CONDITIONS OF THE EUROPEAN TECHNICAL APPROVAL

1 DEFINITION OF PRODUCT AND INTENDED USE

1.1 Definition of the construction product

Norjoist (also trading as Nordic Joist) beams are I-shaped wood-based composite joists. The flanges are produced from planed-all-round (PAR) softwood timber which is finger-jointed. Whilst the majority of the timber is graded in accordance with North American MSR rules some is visually graded with its reference design values being based on the provisions of ASTM D1990.

The web is formed from 9.5mm thick Norbord OSB which is APA graded. The OSB is placed in the beams in sections and 'v' or butt jointed to form a continuous web. The flanges and the web are glued together using Ashland WD3-A322/CX-47 adhesive whilst the flange-flange and web-web joints are made using Ashland UX-100/WD3-A322 adhesive.

This ETA covers joist sizes given in Table A1.1 of Annex 1.

1.2 Intended use

Norjoist beams are intended for use as floor or flat roof joists in building constructions.

With regard to moisture behaviour of the I-joists the use is limited to service class 1 and 2 conditions as defined in Eurocode 5. Under these conditions, where the moisture content does not exceed 20%, the moisture content of OSB will not exceed 14%. The joists may be taken to have a service life of 50 years⁵, provided that there is no mechanical damage or insect attack. (See section 2.7).

2 CHARACTERISTICS OF THE PRODUCT AND METHODS OF VERIFICATION.

The characteristics of Norjoist I-Beams in the range covered by this ETA are summarised in table 2.1.

⁵ An 'assumed intended working life' means that it is expected that, when an assessment following the ETA provisions is made, and when this working life has elapsed, the real working life may be, in normal use conditions, considerably longer without major degradation affecting the essential requirements.

Table 2.1 – Relevant product characteristics appraised in this ETA

	Characteristic of construction product	Corresponding ID* paragraph for works		Product characteristic	ETAG clause for	
					Verification	Assessment
1	Mechanical resistance and stability	4.2	Provisions concerning works or parts of them	4.1.1 Mechanical resistance and stiffness	5.1.1	6.1.1
				4.1.2 Creep and duration of load	5.1.2	6.1.2
				4.1.3 Dimensional stability	5.1.3	6.1.3
				4.1.4 Seismic Actions	5.1.4	6.1.4
2	Safety in case of fire	4.2.3.3.1	Limitation of the generation of fire and smoke within the room. Limitations of spread of smoke beyond the room of origin.	4.2.1. Reaction to fire	5.2.1	6.2.1
		4.2.3.4.2		4.2.2 Fire resistance	5.2.2	6.2.2
3	Hygiene, health and environment	3.3.1.1	Air quality	4.3.1 Wood preservatives	5.3.	6.3
				4.1 Release of dangerous substances	5.3.1	
4	Safety in use	Not relevant				
5	Protection against noise	Not relevant				
6	Energy, economy and heat retention	4.2	Provisions concerning works or parts of them	4.6 Thermal resistance	5.6.1	6.6
Aspects of durability, serviceability and identification				4.7 Durability	5.7.1	6.7.1
				Serviceability	5.7.2	6.7.1
				Identification	5.7.3	6.7.2

* ID = Interpretative Documents. CPD Articles 3 & 12 set out that ID's give concrete form to the Essential Requirements referred to in accordance with the preamble to the Appendix. The principle objective of the ID's is to establish the link between the Essential Requirements and the mandates the Commission gives to CEN & EOTA.

2.1 Mechanical Resistance and Stability (ER1)

The following aspects of performance are relevant to this essential requirement for the I-joists.

2.1.1 Mechanical resistance and stiffness

Mechanical properties for Norjoist beams are given in Annex 2.

2.1.2 Creep and duration of load

Creep and Duration of load factors for Norjoist beams are given in Annex 2.

2.1.3 Dimensional Stability

Nominal dimensions and permissible deviations are given in Annex 3.

2.1.4 Seismic Evaluations

No performance determined.

2.2 Safety in Case of Fire (ER2)

The following aspects of performance are relevant to ER2.

2.2.1 Reaction to Fire

The joists consist of materials classified to have reaction to fire class D-s2, d2 according to table 8 of EN13986 using the classes defined in EN13501-1.

2.2.2 Resistance to Fire

No performance determined⁶.

2.3 Hygiene, Health & Environment (ER3)

2.3.1 Content and/or Release of Dangerous Substances

Based on the declaration of the manufacturer, Norjoists do not contain harmful or dangerous substances as defined in the EU database, but this does not cover EPI (Emulsion Polymer Isocyanate) adhesives. Based on the evidence presented the PMDI adhesive known as WD3-A322/CX-47 and UX-100/WD3-A322 by Ashland Chemicals complies with ASTM D2559 [8] and satisfies type 1 specification to BS EN 301. The product does not contain pentachlorophenol or formaldehyde.

Note:

In addition to the specific clauses relating to dangerous substances contained in this European Technical Approval, there may be other requirements applicable to the products falling within its scope (e.g. transposed European legislation and national laws, regulations and administrative provisions). In order to meet the provisions of the Construction Products Directive, these requirements need also to be complied with, when and where they apply.

⁶ Performance in relation to resistance to fire would be determined for the complete structural element including any associated finishes.

2.4 Safety in Use (ER 4)

Not Relevant

2.5 Protection against Noise (ER 5)

Not Relevant

2.6 Energy Economy and Heat Retention (ER 6)

For thermal resistance no performance is determined.

2.7 Aspects of Durability, Serviceability and Identification

2.7.1 Durability

Norjoist beams can be used in service classes 1 and 2 according to Eurocode 5, and hazard classes 1 and 2 as specified in EN 335. The product may be exposed to the weather for a short time during installation.

The flange and web materials are untreated and so do not withstand attacks from fungi, although black spruce (*Picea mariana*) is classified as slightly durable according to EN 350-2. Durability may also be reduced by attack from insects such as Longhorn beetle, dry wood termites and Common furniture beetle (*Anobium*) in regions where these may be found.

2.7.2 Serviceability

Unacceptable deformation is addressed under 2.1.

2.7.3 Identification

The beams are identified by the Web bearing the mark of the manufacturer of the beam and the CE mark as described in clause 4.

3 EVALUATION AND ATTESTATION OF CONFORMITY AND CE MARKING

3.1 System of attestation of conformity

The system of attestation of conformity 1 applies to Norjoist beams. (See clause 8.1 in section III of ETAG 011).

This system of attestation of conformity provides as follows:

Tasks for the manufacturer:

- 1 Factory production control.
- 2 Testing of samples taken at the factory in accordance with a prescribed test plan.

Tasks for the approved body:

- 3 Initial type–testing of the product;
- 4 Initial inspection of factory and of factory production control;
- 5 Continuous surveillance, assessment and approval of factory production control.

Note: Approved bodies are also referred to as "notified bodies".

3.2 Responsibilities

3.2.1 Tasks for the manufacturer

3.2.1.1 Factory Production Control

The manufacturer shall establish, document and maintain a factory production control system to be endorsed by the notified body, which ensures that the products placed on the market conform to the performance characteristics stated, and that the products are correctly fabricated in accordance with the design.

The factory production control system shall consist of written procedures, regular inspections and tests / assessments to control raw materials and other incoming products / services, equipment, the production process and the finished product. The results of inspections, tests or assessments and subsequent actions shall be recorded. The action taken when control values or criteria are not met shall be recorded.

Manufacturers having a FPC system that complies with EN ISO 9001 and which addresses the requirements of an ETA are recognised as satisfying the FPC requirements of the Directive. EC Guidance Paper B provides for a common basis of understanding factory production control, it is however not mandatory.

3.2.1.2 Factory Testing / Assessment

In this context, testing is taken to mean physical testing and/or visual examination of the product/process. Normally only properties related to the mechanical resistance and stability of the I-joists shall be assessed. For I-joists a visual assessment shall include checks which are detailed in a prescribed test plan, which is part of the factory production control.

All measuring and testing equipment shall be regularly calibrated and inspected according to the documented FPC system. Production records shall be kept for each batch of I-joists for at least 5 years.

3.2.2 Tasks of the approved body

3.2.2.1 Initial Type Testing

Initial type testing has been undertaken under the responsibility of BM TRADA to verify that the production line in question is able to manufacture products in conformity with this ETA. The initial type testing has been limited to testing of the adhesive bonded connections between web and flanges and the shear resistance of the web. Whenever the board is changed, the shear resistance shall be verified by initial type testing.

Whenever a change occurs in materials or production process which would significantly change the above characteristics, the tests or assessments shall be repeated for the appropriate characteristics.

3.2.2.2 Assessment of the factory production control system — initial inspection and continuous surveillance

An assessment of each production unit shall be carried out to demonstrate that the factory production control is in conformity with the ETA and any subsidiary information. This assessment shall be based on an initial inspection of the factory. Subsequently continuous surveillance of factory production control, including verification that tests are being carried out to the prescribed test plan, is necessary to ensure continuing conformity with the ETA.

It is recommended that surveillance inspections shall be conducted at least twice per year.

3.2.2.3 Certification of Conformity

When all the criteria of the Conformity Attestation are satisfied the approved certification body shall issue a Certificate of conformity for the product described within this ETA

4 CE MARKING AND INFORMATION

The CE mark shall be affixed:

- On the Norjoist I-Beam itself, or
- On an attached label, or
- On the packaging, or
- On the accompanying commercial documents.

According to the CE Guidance Paper D on CE marking, the required information to accompany the symbol "CE" is:

- Identification number of the notified certification body (AOC System 1)
- The name or identifying mark of the producer and the registered address of the producer
- Last two digits of the year in which the marking was affixed
- The number of the EC certificate of conformity (AOC System 1)
- Number of the ETA, valid as indication to identify the characteristics of the I-joist.

5 ASSUMPTIONS UNDER WHICH THE FITNESS OF THE PRODUCTS FOR THE INTENDED USE WAS FAVOURABLY ASSESSED

5.1 Manufacturing

The Norjoist I-Beams are manufactured in the factory in accordance with the provisions of this European Technical Approval as identified during inspection of the plant by BM TRADA.

Changes to the product or production process, which could result in this deposited data/information being incorrect, should be notified to BM TRADA before the changes are introduced. BM TRADA will decide whether or not such changes affect the ETA and consequently the validity of the CE marking on the basis of the ETA and if so whether further assessment or alterations to the ETA, shall be necessary.

5.2 Installation

Refer to Annex 4 for installation instructions.

5.3 Responsibility of the manufacturer

It is the manufacturer's responsibility to ensure that the relevant information is given to specifiers and end users. This information may take the form of reproduction of the relevant parts of the European Technical Approval. In addition all installation data shall be shown clearly on the packaging and/or on an enclosed instruction sheet.

The minimum data required is:

- Clear designation of upper and lower flanges
- Minimum bearing length at the support
- Information on storage and lifting
- Identification of batch number of manufacture

6 RECOMMENDATIONS

6.1 Packaging, transport and storage

Norjoist I-Beams shall be protected against harmful wetting during transport and storage. The joists will arrive on site with a typical flange moisture content of 16%.

The beams must not be lifted or stored in such a way that bending around the weak axis may cause damage to the beams. On site the joists should be stacked on edge and stored out of ground contact.



Norjoist I-Beams shall be stored to minimize changes in moisture content, caused by the weather, by storing under cover but permit free passage of air.

They should be protected from excessive sun, rain or moisture. Site storage is intended to be temporary, prior to erection. The fabrication and delivery of joists should therefore be arranged to minimize the storage time, both at the fabricator's premises and on site.

Nordic Engineered Wood recommends that the joists be wrapped in protective plastic covering, to protect the beams from short-term exposure to inclement weather.

The manufacturer must ensure that the information of these provisions is given to those concerned.

Beams damaged during storage or transport must be discarded. Only sound beams should be installed.

On behalf of BM TRADA Certification.	
Signature:	
Name:	Mr Robert Foster
Title:	Technical Certification Manager

ANNEX 1 - DESCRIPTION OF PRODUCT(S)

Figure A1 Cross-section of the Norjoist Beam.

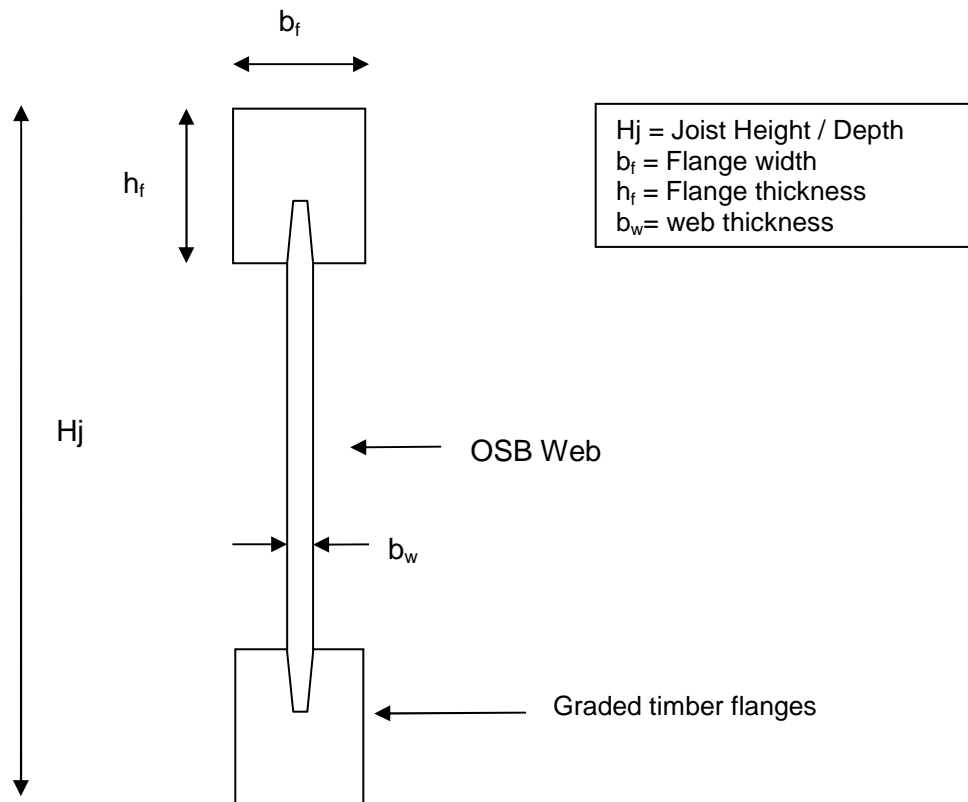

Table A1.1 Norjoist product range and dimensions.

Joist designation	Joist depth (mm)	Flange dimensions $h_f \times b_f$ (mm)	Web thickness b_w (mm)	Web Orientation	Joist weight (Kgm^{-1})
$7\frac{7}{8}$ " NI-40x	200	38 × 63	9.5	Parallel	3.50
$7\frac{7}{8}$ " NI-60					3.79
$7\frac{7}{8}$ " NI-80		38 x 89			4.54
$8\frac{21}{32}$ " NI-40x	220	38 × 63	9.5	Parallel	3.65
$8\frac{21}{32}$ " NI-60					3.94
$8\frac{21}{32}$ " NI-80		38 x 89			4.69
$9\frac{1}{4}$ " NI-20	235	38 × 63	9.5	Parallel	3.79
$9\frac{1}{4}$ " NI-40x					3.88
$9\frac{1}{4}$ " NI-80		38 x 89			4.69
$9\frac{1}{2}$ " NI-20	241	38 × 63	9.5	Parallel	3.79
$9\frac{1}{2}$ " NI-40					3.94
$9\frac{1}{2}$ " NI-40x					3.94
$9\frac{1}{2}$ " NI-60					4.14
$9\frac{1}{2}$ " NI-80		38 x 89			4.87
$11\frac{1}{4}$ " NI-20	286	38 × 63	9.5	Parallel	4.09
$11\frac{1}{4}$ " NI-40x					4.18
$11\frac{1}{4}$ " NI-80		38 x 89			5.04
$11\frac{7}{8}$ " NI-20	302	38 × 63	9.5	Parallel	4.24
$11\frac{7}{8}$ " NI-40					4.24
$11\frac{7}{8}$ " NI-40x					4.24
$11\frac{7}{8}$ " NI-60					4.45
$11\frac{7}{8}$ " NI-80		38 x 89			5.13
14" NI-40	356	38 × 63	9.5	Perpendicular	4.46
14" NI-40x					4.46
14" NI-60		38 x 89			4.69
14" NI-80					5.58
16" NI-40	406	38 × 63	9.5	Perpendicular	4.91
16" NI-40x					4.91
16" NI-60		38 x 89			5.15
16" NI-80					5.88

Table A1.2 Characteristic strength, modulus of elasticity and rigidity values for joist flanges to be used in calculations.

Joist series		NI-20	NI-40	NI-40x	NI-60	NI-80
Bending strength – parallel to grain (N/mm ²)	$f_{m,k}$	12.67	23.89	26.06	30.41	30.41
Tensile strength– parallel to grain (N/mm ²)	$f_{t,k}$	15.56	16.51	17.37	22.80	22.80
Compression strength– parallel to grain (N/mm ²)	$f_{c,k}$	15.07	22.27	22.93	24.56	24.56
Shear strength– parallel to grain (N/mm ²)	$f_{v,k}$	1.95	1.95	1.95	2.32	2.32
Bending stiffness parallel to grain – mean (N/mm ²)	E_{mean}	8274	10687	11997	12755	12755
Bending stiffness parallel to grain – min (N/mm ²)	$E_{0.05}$	4871	8753	9826	10447	10447

It should be noted that Norjoist upgrade their timber strength values above and beyond that specified in APA documentation through In-house QA testing. It is recommended that when carrying out CE surveillance audits the auditor should make note to check the In-house QA data to ensure that the characteristic strength achieved during testing is equal to or above that quoted in Table A2.1.

Table A1.3 Web Properties for all Joist Series.

For all joist series		
Axial tensile strength parallel to the manufacturing direction (N/mm ²)	$f_{t,0,k}$	7.40
Axial compression strength parallel to the manufacturing direction (N/mm ²)	$f_{c,0,k}$	8.29
Axial tensile strength perpendicular to the manufacturing direction (N/mm ²)	$f_{t,90,k}$	2.50
Axial compression perpendicular to the manufacturing direction (N/mm ²)	$f_{c,90,k}$	7.28
Panel shear strength (N/mm ²)	f_v	5.98
Panel shear stiffness (N/mm ²)	G_v	1425
Axial stiffness (in tension or compression) parallel to the manufacturing direction (N/mm ²)	$E_{axial,0,k}$	5233
Axial stiffness (in tension or compression) perpendicular to the manufacturing direction (N/mm ²)	$E_{axial,90,k}$	3830

ANNEX 2 – MECHANICAL PROPERTIES

Table A2.1 *Characteristic strength and stiffness properties together with weight per metre length.*

Joist Designation	Depth (mm)	Bending moment capacity M (kNm)	Bending stiffness capacity EI (10^{12} Nmm ²)	Shear strength capacity V (kN)	Shear stiffness capacity GA (10^6 N)	Intermediate reaction capacity ¹⁾ IR (kN)	End reaction capacity ²⁾ ER (kN)	Weight Per metre length (kg/m)
7 ⁷ / ₈ NI-40x	200	6.58	0.387	9.28	1.991	19.92	9.28	3.50
7 ⁷ / ₈ NI-60		8.64	0.410	9.28	1.991	19.92	9.28	3.79
7 ⁷ / ₈ NI-80		12.21	0.575	9.28	1.991	19.92	9.28	4.54
8 ⁵ / ₈ NI-40x	220	7.39	0.487	10.33	2.263	19.92	9.28	3.65
8 ⁵ / ₈ NI-60		9.70	0.517	10.33	2.263	19.92	9.28	3.94
8 ⁵ / ₈ NI-80		13.71	0.725	10.33	2.263	19.92	9.28	4.69
9 ¹ / ₄ NI-20	235	6.79	0.399	11.39	2.470	17.92	9.49	3.79
9 ¹ / ₄ NI-40x		7.99	0.571	12.33	2.466	21.07	10.54	3.88
9 ¹ / ₄ NI-80		14.83	0.848	12.33	2.466	23.61	11.81	4.69
9 ¹ / ₂ NI-20	241	7.01	0.426	11.81	2.556	17.92	9.49	3.79
9 ¹ / ₂ NI-40		7.84	0.543	11.81	2.552	21.07	10.54	3.94
9 ¹ / ₂ NI-40x		8.25	0.609	12.65	2.552	23.61	11.81	3.94
9 ¹ / ₂ NI-60		10.83	0.646	12.65	2.552	23.61	11.81	4.14
9 ¹ / ₂ NI-80		15.31	0.904	12.65	2.552	25.09	12.55	4.87
11 ¹ / ₄ NI-20	286	8.54	0.638	14.13	3.160	18.98	9.49	4.09
11 ¹ / ₄ NI-40x		10.04	0.907	14.86	3.155	28.99	13.18	4.18
11 ¹ / ₄ NI-80		18.65	1.344	14.86	3.155	27.12	14.02	5.04
11 ⁷ / ₈ NI-20	302	9.08	0.724	14.97	3.375	18.98	9.49	4.24
11 ⁷ / ₈ NI-40		10.15	0.919	14.97	3.371	25.25	12.12	4.24
11 ⁷ / ₈ NI-40x		10.68	1.029	15.60	3.371	28.99	13.18	4.24
11 ⁷ / ₈ NI-60		14.02	1.091	15.60	3.371	28.99	13.18	4.45
11 ⁷ / ₈ NI-80		19.84	1.523	15.60	3.371	30.57	14.02	5.13
14 NI-40x	356	12.86	1.506	17.81	4.104	28.99	13.18	4.46
14 NI-60		16.88	1.595	17.81	4.104	28.99	13.18	4.69
14 NI-80		23.89	2.221	18.24	4.104	32.09	14.02	5.58
16 NI-40x	406	14.91	2.043	17.28	4.794	28.99	13.18	4.91
16 NI-60		19.58	2.163	17.28	4.794	28.99	13.18	5.15
16 NI-80		27.70	3.004	20.77	4.794	34.89	14.02	5.88

1) The bearing capacities given are for a minimum bearing length of 89mm
2) The bearing capacities given are for a minimum bearing length of 44mm

Table A2.2 Values of k_{mod} for Norjoist Beams.

Duration of load	Bending and axial resistance		Shear resistance	Bearing resistance
	<i>Service class 1</i>	<i>Service class 2</i>	<i>Service class 1 & 2</i>	<i>Service class 1 & 2</i>
Permanent	0.60	0.60	0.30	0.30
Long term	0.70	0.70	0.40	0.40
Medium term	0.80	0.80	0.55	0.55
Short term	0.90	0.90	0.70	0.70
instantaneous	1.10	1.10	0.90	0.90

Table A2.3 Values of k_{def} for Norjoist Beams.

Bending and axial deformation		Shear deformation
<i>Service class 1</i>	<i>Service class 2</i>	<i>Service class 1 & 2</i>
0.60	0.80	2.25

ANNEX 3 – DIMENSIONAL STABILITY

Norjoist beams are manufactured following documented quality control systems. Quality control procedures include checks on web, flange and adhesive materials for specification and moisture content, dimensional checks before and after preparation, verification of adhesive spread, fit of component parts and curing temperature. Manufacturing tolerances are given in Table A3.1. Regular tests are undertaken to monitor adhesive bond on the web-flange connections, shear strength and the strength of completed joists.

Table A3.1 Manufacturing Tolerances.

<i>Member Dimension</i>	<i>Manufactured Tolerance (mm)*</i>
<i>Overall joist length (mm)</i>	$\pm 12.5^{(1)}$
<i>Overall joist height</i>	$-3.2 +0.0$
<i>Flange thickness</i>	-1.6
<i>Flange width</i>	± 0.8
<i>Web thickness (for OSB)</i>	± 0.8

* At manufacturing moisture content

⁽¹⁾ Depending on length.

ANNEX 4 – INSTALLATION INSTRUCTIONS

The technical manual of the manufacturer shall be followed, current examples of details are given below. The following points are especially critical.

1. Norjoists shall be installed on the basis of a specific structural design for each installation, using the load-bearing capacities given in Annex 2 of this ETA.
2. Actions at joist supports shall not exceed the bearing resistance given in Annex 2.
3. The joists shall be installed by appropriately qualified personnel, following an installation plan and relevant construction details worked out for each individual building project. The installation plan shall be based on the manufacturer's general guide and provisions for installing Norjoists.
4. Temporary bracing should be used to keep the Norjoists in a straight and plumb position during installation and to avoid instability. I-joists should be handled similar to solid timber beams, except that their strength and stiffness is less around their minor axis. Hence care must be taken to ensure that joists are not damaged during handling due to bending around this axis.
5. Flooring is to be fixed to the top flange of the joists. The maximum spacing between fixings should be 400mm.
6. The flanges must not be drilled, notched or material otherwise removed on site.
7. Significantly damaged I-joists should not be used.
8. In common with similar timber based products, it is recommended that eye protection and dust masks be used when cutting.
9. Rigid service pipes can be incorporated within the floor or roof void, by passing through the perforated knockout holes in the Norjoists.

The manufacturer shall ensure that the information of these provisions is given to those concerned.